



User Manual

EE872

Modular Probe for CO₂, RH, T and p

YOUR PARTNER IN SENSOR TECHNOLOGY



ELEKTRONIK[®]
Ges.m.b.H.

E+E Elektronik Ges.m.b.H. does not accept warranty and liability claims neither upon this publication nor in case of improper treatment of the described products.

The document may contain technical inaccuracies and typographical errors. The content will be revised on a regular basis. These changes will be implemented in later versions. The described products can be improved and changed at any time without prior notice.

© Copyright E+E Elektronik Ges.m.b.H. All rights reserved.

EMC note USA (FCC):

This equipment has been tested and found to comply with the limits for a Class A digital device, pursuant to part 15 of the FCC Rules. These limits are designed to provide reasonable protection against harmful interference when the equipment is operated in a commercial environment. This equipment generates, uses, and can radiate radio frequency energy and, if not installed and used in accordance with the instruction manual, may cause harmful interference to radio communications. Operation of this equipment in a residential area is likely to cause harmful interference in which case the user will be required to correct the interference at his own expense.

EMC note Canada (ICES-003):

CAN ICES-3 (A) / NMB-3 (A)

CONTENT

1	General	4
1.1	Explanation of Symbols	4
1.2	General Safety Instructions	4
1.3	Environmental Aspects	4
1.4	Mounting, Start-up and Operation	5
2	Scope of Supply	5
3	Product Description	5
3.1	Operation Principle	5
3.2	Dimensions	6
3.3	Electrical Connection	6
3.4	Hardware Selection between Analogue Output and RS485 Interface with Modbus RTU or BACnet MS/TP	7
4	Installation	7
5	Setup and Adjustment	8
5.1	PCS10 Product Configuration Software	8
5.2	RS485 Digital Interface	8
5.2.1	BACnet Protocol Settings	8
5.2.2	Modbus RTU Protocol Settings	9
5.2.3	Modbus Register Map	9
5.2.4	Modbus Reading Example	10
5.3	Error Indication on the Analogue Output (NAMUR)	10
6	Maintenance	11
6.1	Replacing the Sensing Module EE872S	11
6.2	Changing the Filter Cap	11
6.3	EE872 Adjustment or Calibration with Reference CO ₂ Gas	11
6.4	Protection of EE872 During Site Cleaning Application	12
7	Accessories	12
8	Spare Parts	12
9	Technical Data	13

1 General

This user manual serves for ensuring proper handling and optimal functioning of the device. The user manual shall be read before commissioning the equipment and it shall be provided to all staff involved in transport, installation, operation, maintenance and repair.



Please find this document and further product information on our website at www.epluse.com/ee872.

The user manual may not be used for the purposes of competition without the written consent of E+E Elektronik® and may not be forwarded to third parties. Copies may be made for internal purposes. All information, technical data and diagrams included in these instructions are based on the information available at the time of writing.

Intended use

The EE872 modular probe is intended for the measurement of CO₂, relative humidity (RH), temperature (T) and ambient pressure (p). Additionally, the device calculates the dew point temperature (Td). The probe is designed for the use in harsh and demanding environments such as agriculture, life stock barns, hatchers, incubators, green houses or outdoors. The use of the EE872 other than described in this manual is not recommended.

The manufacturer cannot be held responsible for damages as a result of incorrect handling, installation and maintenance of the device. Unauthorized modifications of the product lead to loss of all warranty claims. The device may only be powered with a power supply class III ⚡ (Europe) or with a class 2 supply (North America).

Disclaimer

The manufacturer or his authorized agent can be only be held liable in case of willful or gross negligence. In any case, the scope of liability is limited to the corresponding amount of the order issued to the manufacturer. The manufacturer assumes no liability for damages incurred due to failure to comply with the applicable regulations, operating instructions or the specified operating conditions. Consequential damages are excluded from the liability.

1.1 Explanation of Symbols



This symbol indicates safety information.

It is essential that all safety information is strictly observed. Failure to comply with this information can lead to personal injuries or damage to property. E+E Elektronik® assumes no liability if this happens.



This symbol indicates instructions.

The instructions shall be observed in order to reach optimal performance of the device.



This symbol indicates environmental information.

The instructions shall be observed for the most environmentally friendly operation and disposal.

1.2 General Safety Instructions



- The device and mainly the filter cap shall not be exposed to unnecessary mechanical stress.
- Installation, electrical connection, maintenance and commissioning shall be performed by qualified personnel only.
- Use the EE872 only as intended and observe all technical specs. The device must be operated with the filter cap on at all times.
- This device is not appropriate for safety, emergency stop or other critical applications where device malfunction or failure could cause injury to human beings.

1.3 Environmental Aspects



Products from E+E Elektronik® are developed and manufactured observing of all relevant requirements with respect to environment protection. Please observe local regulations for the device disposal.



For disposal, the individual components of the device shall be separated according to local recycling regulations. The electronics shall be disposed of correctly as electronics waste.

1.4 Mounting, Start-up and Operation

The device has been produced under state of the art manufacturing conditions, has been thoroughly tested and has left the factory fulfilling all safety criteria. The manufacturer has taken all precautions to ensure safe operation of the device. The user must ensure that the device is set up and installed in a manner that does not have a negative effect on its safe use.

The user is responsible for observing all applicable safety guidelines, local and international, with respect to safe installation and operation on the device. This user manual contains information and warnings that must be observed by the user in order to ensure safe operation.



- Mounting, start-up, operation and maintenance of the device may be performed by qualified staff only. Such staff must be authorized by the plant operator to carry out the mentioned activities.
- The qualified staff must have read and understood this user manual and must follow the instructions contained within.
- All process and electrical connections shall be thoroughly checked by authorized staff before putting the system into operation.
- Do not install or start-up a device supposed to be faulty. Make sure that such devices are not accidentally used by marking them clearly as faulty.
- A faulty device may only be investigated and possibly repaired by qualified, trained and authorized staff. If the fault cannot be fixed, the device shall be removed from the system.
- Service operations other than described in this user manual may only be performed by the manufacturer.

2 Scope of Supply

- EE872 according to ordering guide
- Test report according to DIN EN10204-2.2
- Quick User Guide

3 Product Description

3.1 Operation Principle

The EE872 is available in two versions:

EE872-M10...: The probe measures the CO₂ concentration. The sensing module is heated by factory default setting to prevent condensation. The CO₂ measurement value is available on the analogue output or on the digital interface.

EE872-M13...: The probe measures CO₂, RH, T and p, and calculates Td. Since per factory default the sensing module is not heated, the accurate measurement of RH and T is possible. In case the user activates the probe heating, the RH and T data is not available. The calculated Td value is still available. All values are available on the digital interface only.

All versions provide CO₂ measurement T and p compensated.

The CO₂ measurement is based on the dual wavelength/dual detector NDIR principle. Infrared light is led through the gas to be examined. One detector is tuned to 4.2 μm, which is the wavelength absorbed by CO₂. The second detector is tuned to 3.9 μm, a wavelength that is not affected by any gas. The CO₂ concentration is calculated from the different outputs of the two according detectors. For more information, please see [E+E's paper on the principles of CO₂ measurement](#).



Please note: Changing the factory setup with respect to heating (on/off) may lead to an additional measurement error, which might get the CO₂ measurement accuracy out of specification.

3.2 Dimensions

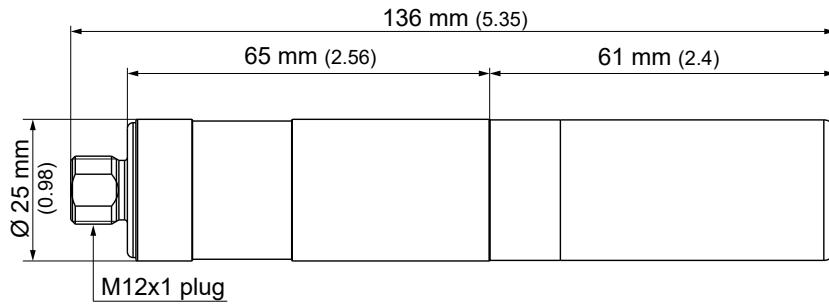

Fig. 1 Dimensions of EE872 in mm (inch)

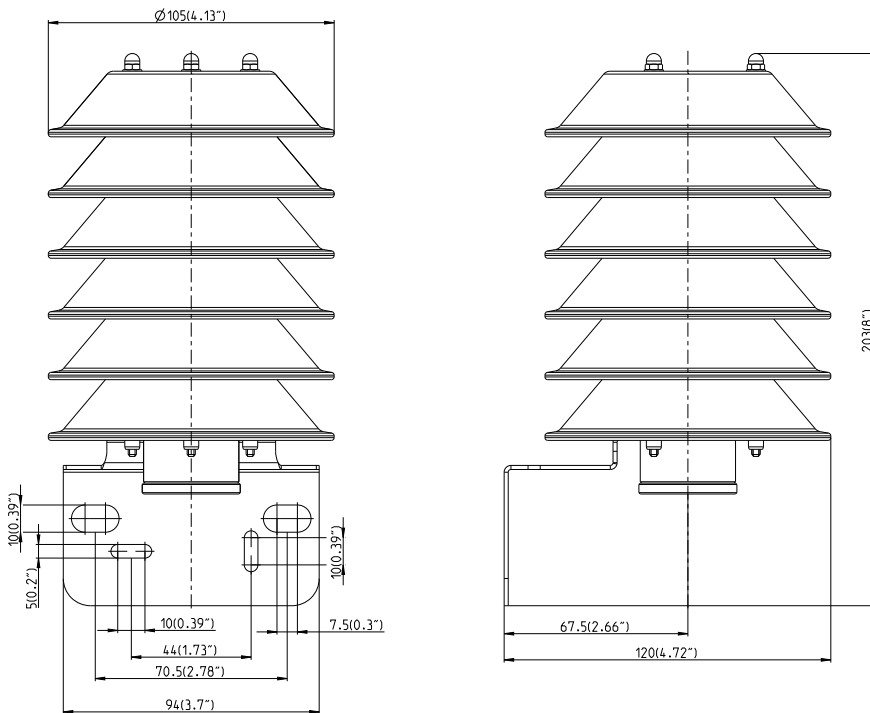

Fig. 2 Dimensions of optional radiation shield (accessory HA010510)

3.3 Electrical Connection



Important note:

The manufacturer cannot be held responsible for personal injuries or damage to property as a result of incorrect handling, installation, wiring, power supply and maintenance of the device.

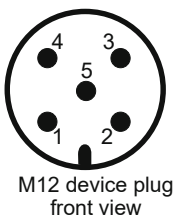

M12 device plug front view

Pin number	Function	Wire colors for accessories: - Couplig flange HA010705 - Connection cable HA010819/820/821
1	Supply voltage	brown
2	B RS485 (D-) or voltage output	white
3	GND	blue
4	A RS485 (D+) or current output	black
5	Configuration pin	gray

Fig. 3 Pin and flying leads assignment

3.4 Hardware Selection between Analogue Output and RS485 Interface with Modbus RTU or BACnet MS/TP

The “default output” of the EE872 can be analogue, Modbus RTU or BACnet MS/TP. The “default output” of a new EE872 corresponds to the ordered type number, refer to the EE872 datasheet. In case the user altered the factory setup, the “default output” corresponds to the latest settings uploaded to the EE872 by means of the PCS10 Product Configuration Software (refer to the help function of PCS10).

	Default: analogue	Default: Modbus RTU	Default: BACnet MS/TP
Pin 5 open (=HIGH)	10 s timeout ¹⁾ , then analogue output	Modbus RTU	10 s timeout ¹⁾ , then BACnet MS/TP ¹⁾
Pin 5 GND (=LOW)	Analogue	Analogue	BACnet MS/TP

1) For configuration purposes, during the first 10 seconds after power on the EE872 awaits connection with the PCS10 Product Configuration Software.

Tab. 1 Function of the configuration pin (pin 5 of M12 connector)

4 Installation

Best measurement performance is achieved when the entire probe is located inside the environment to be monitored. This is the case, for example, when the EE872 is fixed onto a wall with the **mounting clip HA010227** (not included in the scope of supply, see data sheet “Accessories”), or freely hangs from the ceiling on the connection cable.

i The probe can be installed also into a partition wall using the stainless steel **mounting flange HA010226** (not included in the scope of supply, see data sheet “Accessories”).

For large temperature difference between the two sides of the wall, T gradients may appear along the probe. Although the CO₂ measurement is T compensated, these gradients have a great impact on the RH and T accuracy in the M13 model. Therefore, it is of paramount importance to minimize the temperature gradients. The part of the probe standing out of the wall on the connection side shall be as small as possible and well thermally insulated.

i For best RH and T accuracy, model M13 shall be installed horizontally or with the filter cap positioned downwards.



EE872 with mounting flange HA010226



EE872 with mounting clip HA010227

i For outdoor applications the EE872 must be used with the radiation shield HA010510 (not included in the scope of supply, see data sheet “Accessories”), which protects the device against rain, snow, ice and solar radiation.

5 Setup and Adjustment

The EE872 is ready to use and does not require any configuration by the user. The factory setup of EE872 corresponds to the type number ordered. Please see chapter 3.1 for a model overview and the data sheet at www.epluse.com/ee872. The user can change the factory setup by using the Modbus configuration adapter (order code HA011018) and the PCS10 Product Configuration Software. For this, pin 5 must be open (=HIGH), see chapter 3.4.

An EE872 set originally to analogue output can be changed to RS485 interface and vice versa. One can change the CO₂ output signal type (analogue to RS485/Modbus RTU or RS485/BACnet MS/TP and vice versa), the analogue output scaling and the digital settings. For p measurement, an offset correction is possible. The CO₂, RH and T measurement is offset and 2-point adjustable.

In addition, it is possible to enable or disable the pressure compensation (factory setting: enabled), the sensing module heating (factory setting according to the model ordered) and the NAMUR error indication (factory setting: disabled).



Please note: The EE872 may not be connected to any additional power supply when using the Modbus configuration adapter HA011018.



Fig. 4 Modbus configuration adapter HA011018

Please note: By changing the EE872 configuration, the product and the packaging label lose their validity. Please see “Relabeling in case of product configuration changes” at http://downloads.epluse.com/fileadmin/data/product/Configuration/Configuration_e.pdf.

5.1 PCS10 Product Configuration Software

1. Download the PCS10 Product Configuration Software from www.epluse.com/pcs10 and install it on the PC.
2. Connect the E+E device to the PC using the Modbus configuration cable.
3. Start the PCS10 software.
4. Follow the instructions on the PCS10 opening page for scanning the ports and identifying the connected device.
5. Click on the desired setup or adjustment mode from the main PCS10 menu on the left and follow the online instructions of the PCS10.

5.2 RS485 Digital Interface

5.2.1 BACnet Protocol Settings

	Factory settings	User selectable values (via PCS10)
Baud rate	As per type number ordered	9 600, 19 200, 38 400, 57 600, 76 800, 115 200
Data bits	8	8
Parity	None	None
Stop bits	1	1
BACnet address	6	0...127

Tab. 2 BACnet protocol settings



The recommended settings for multiple devices in a BACnet MS/TP network are 38 400, 8, None, 1.

The EE872 PICS (Product Implementation Conformance Statement) is available on the E+E website at www.epluse.com/ee872.

BACnet address and baud rate can be set via:

1. PCS10 Product Configuration Software and the Modbus configuration adapter HA011018.
2. BACnet protocol, see the PICS.

5.2.2 Modbus RTU Protocol Settings

	Factory settings	User selectable values (via PCS10)
Baud rate	As per type number ordered	9600, 19200, 38400
Data bits	8	8
Parity	Even	None, odd, even
Stop bits	1	1, 2
Modbus address	237	1...247

Tab. 3 Modbus RTU protocol settings



The recommended settings for multiple devices in a Modbus RTU network are 9600, 8, even, 1. The EE872 represents 1/10 unit load on an RS485 network.

Device address, baud rate, parity and stop bits can be set via:

1. PCS10 Product Configuration Software and the Modbus configuration adapter HA011018.
The PCS10 can be downloaded free of charge from www.epluse.com/pcs10.
2. Modbus protocol in the register 60001 (0x00) and 60002 (0x01). See Application Note Modbus AN0103 (available at www.epluse.com/ee872)

The serial number as ASCII-code is located at read register address 30001-30008 (16 bit per address). The firmware version is located at register address 30009 (bit 15...8 = major release; bit 7...0 = minor release). The sensor name is located at register address 30010.

INTEGER 16 bit		
Parameter	Register number ¹⁾ [DEC]	Protocol address ²⁾ [HEX]
Read and write register: function code 0x03 / 0x06		
Slave-ID Modbus address	0001	0x00
Modbus protocol settings ³⁾	0002	0x01

INFO (read register):		
Parameter	Register number ¹⁾ [DEC]	Protocol address ²⁾ [HEX]
Read and write register: function code 0x03 / 0x04		
Serial number (as ASCII)	0001	0x00
Firmware version	0009	0x08
Sensor Name	0010	0x09

1) Register number starts from 1.

2) Protocol address starts from 0.

3) For Modbus protocol settings see Application Note Modbus AN0103 (available at www.epluse.com/ee872).

5.2.3 Modbus Register Map

The measured data is saved as 32 bit floating point values (data type FLOAT) and as 16 bit signed integer values (data type INTEGER):

FLOAT 32 bit			
Parameter	Unit	Register number ¹⁾ [DEC]	Protocol address ²⁾ [HEX]
Read register: function code 0x03 / 0x04			
CO ₂ (average)	ppm	1061	0x424
CO ₂ (raw)	ppm	1063	0x426
Pressure p*	mbar	1201	0x4B0
Pressure p*	psi	1203	0x4B2
Relative humidity RH**	%	1021	0x3FC
Temperature T**	° C	1003	0x3EA
Temperature T**	° F	1005	0x3EC
Temperature T**	K	1009	0x3F0
Dew point temperature Td***	° C	1105	0x450
Dew point temperature Td***	° F	1107	0x452
Dew point temperature Td***	K	1147	0x47A

Tab. 4 Floating point values (read register)

INTEGER 16 bit				
Parameter	Unit	Scale ³⁾	Register number ¹⁾ [DEC]	Protocol address ²⁾ [HEX]
Read register: function code 0x03 / 0x04				
CO ₂ (average)	ppm	1	4031	0xFBE
CO ₂ (raw)	ppm	1	4032	0xFBF
Pressure p*	mbar	10	4101	0x1004
Pressure p*	psi	100	4102	0x1005
Relative humidity RH**	%	100	4011	0xFAA
Temperature T**	° C	100	4002	0xFA1
Temperature T**	° F	50	4003	0xFA2
Temperature T**	K	50	4005	0xFA4
Dew point temperature Td***	° C	100	4053	0xFD4
Dew point temperature Td***	° F	100	4054	0xFD5
Dew point temperature Td***	K	100	4074	0xFE9

Tab. 5 Integer values (read register)

* available for version M13

** available for version M13 only when probe is not heated (default setting)

*** available for version M13 always: enabling or disabling the probe heating does not affect the Td measurement

1) Register number starts from 1.

2) Protocol address starts from 0.

3) Examples: For scale 100, the reading of 2550 means a value of 25.5. For scale 50, the reading of 2550 means a value of 51.

5.2.4 Modbus Reading Example

Example of MODBUS RTU command for reading the CO₂ (float value) CO₂ = 1288,34375 ppm from the register 0x424:

Device EE872; slave ID 237 (0xED)

Reference document, chapter 6.3: http://www.modbus.org/docs/Modbus_Application_Protocol_V1_1b.pdf

	Modbus ID address	Function code	Starting address Hi	Starting address Lo	No. of register Hi	No. of register Lo	CRC	
Request [Hex]:	ED	03	04	24	00	02	93	9C

	Modbus ID address	Function code	Byte count	Register 1 value Hi	Register 1 value Lo	Register 2 value Hi	Register 2 value Lo	CRC	
Response [Hex]:	ED	03	04	0B	00	44	A1	27	61

Decoding of float values:

Float values are stored according to the IEEE754 standard. The byte pairs 1, 2 and 3, 4 are inverted as follows:

MMMMMMMM	MMMMMMMM	SEEEEEEE	EMMMMMMM
Byte 3	Byte 4	Byte 1	Byte 2

Example:

Response [Hex]				Value in decimal
Byte 1 (Register 2 - Hi)	Byte 2 (Register 2 - Lo)	Byte 3 (Register 1 - Hi)	Byte 4 (Register 1 - Lo)	
44	A1	0B	00	1288.34375

See also Application Note AN0103 at www.epluse.com/ee872.

5.3 Error Indication on the Analogue Output (NAMUR)

The EE872 features an error indication on the analogue output according to the NAMUR NE 043 recommendations (Standardization of the Signal Level for the Failure Information of Digital Transmitters, Edition 2003-02-03, see www.namur.net/en/recommendations-and-worksheets/current-nea.html).

The feature is disabled by factory default and can be enabled with the PCS10 Product Configuration Software, see above.

Output signal	NAMUR signal level
0 - 5 V	5.5 V
0 - 10 V	11 V
4 - 20 mA	21 mA
0 - 20 mA	21 mA

6 Maintenance

6.1 Replacing the Sensing Module EE872S

If needed, the sensing module can be replaced by a new one. Please refer to chapter 8 for the order code.

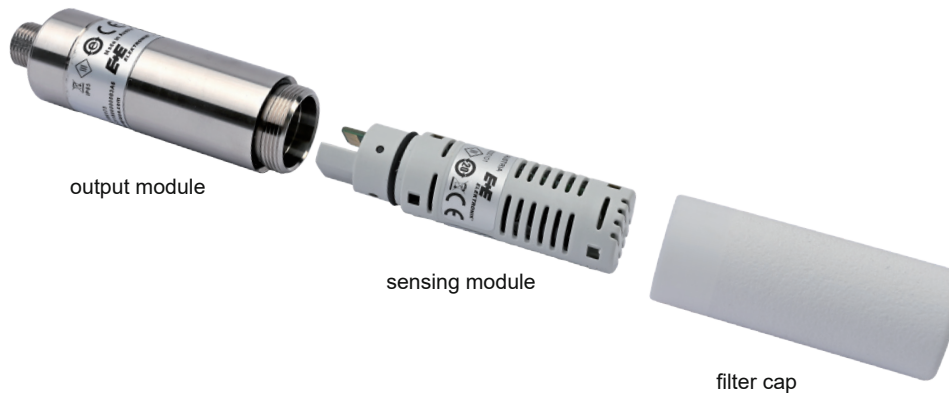

Fig. 5 EE872 modular construction



Extreme working conditions such as highly polluted, aggressive and chemically contaminated environment might require periodical maintenance of the device. The maintenance is facilitated by the modular design. The replacement of the sensor module under above conditions represents a standard maintenance operation, whereby the sensor module is a wear component. A possible measurement drift or the failure of the sensing module caused by harsh working environment are excluded from any warranty claims.



Please note:

The new sensing module EE872S must feature same CO₂ measuring range as the original EE872 probe! If the measuring range of the replacement module and of the original EE872 probe are different, the analogue output will stay at 4 mA, 0 V or NAMUR error indication while the CO₂ reading via RS485 interface will be 0 ppm.



Procedure:

- » Power off the EE872.
- » Remove the filter cap by turning it counter-clockwise.
- » Remove the sensing module by pulling it straight out from the output module.
- » Plug the new EE872S sensing module into the output module.
- » Screw the filter cap fingertight onto the probe.

6.2 Changing the Filter Cap

In a dusty, polluted environment it might be necessary to replace the filter cap once in a while. In most of the cases, a clogged filter shows visible contamination or dirt. Longer response time of the CO₂ measurement also indicates a clogged filter cap. In such cases, replace the filter by a new, original one, see data sheet "Accessories".



Procedure:

- » Turn the filter cap counter-clockwise for removing it.
- » Install the new filter cap fingertight by turning it clockwise.

6.3 EE872 Adjustment or Calibration with Reference CO₂ Gas

Definitions:

Adjustment: the specimen is brought in line with the reference.

Calibration: the specimen is compared with a reference and its deviation from the reference is documented.

For EE872 calibration or adjustment with reference CO₂ gas use the calibration adapter HA010785 (not included in the scope of supply, see data sheet "Accessories").

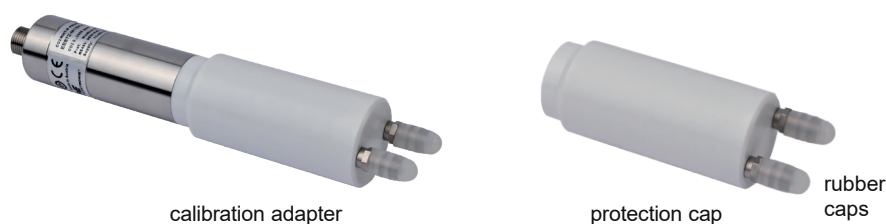

Fig. 6 Calibration adapter HA010785 (with mounted rubber caps for use as protection cap)



Procedure:

- » Remove the filter cap and install the calibration adapter onto the probe.
- » Connect the calibration gas to one of the two connection nipples. The gas fed into the calibration adapter shall freely flow out through the second nipple.
- » Set the flow rate to 0.1...1.0 l/min and consider a stabilization time of 10 min.



Please note:

- For best accuracy of the calibration procedure, the temperature difference between reference gas and probe should be as low as possible.
- Adjustment/calibration shall be performed with the factory settings activated concerning sensing module heating and pressure compensation.

6.4 Protection of EE872 During Site Cleaning Application

The calibration adapter (HA010785) can also be used as a protection cap, for instance if the device remains on the measuring site during cleaning operations. For this purpose, close both nipples with the supplied rubber caps.

In case the probe is removed from the site, it is recommended to apply the protection cap for the M12 cable socket (HA010781) and the one for the EE872 M12 plug of (HA010782).

7 Accessories

- E+E Product Configuration Software (Free download from www.epluse.com/pcs10) PCS10
- Modbus configuration adapter HA011018
- Connection cable M12 - flying leads
1.5 m (59.06") / 5 m (196.85") / 10 m (393.70") HA010819/20/21
- T-coupler M12 - M12 HA030204
- M12x1 connector, 5 pole, for self assembly HA010708
- Protection cap / calibration adapter HA010785
- Protection cap for the M12 cable socket HA010781
- Protection cap for the M12 plug of EE872 HA010782
- Mounting flange HA010226
- Wall mounting clip Ø 25 mm HA010227
- Radiation shield HA010510
- M12x1 flanged coupling with 50 mm (1.97") stranded wire HA010705

8 Spare Parts

- PTFE filter cap HA010123
- Catalytic filter cap for H₂O₂ sterilization HA010124
- Replacement sensing module EE872S-...

		EE872S-
Model	CO ₂ (default: heated)	M10
	CO ₂ + T + RH + p (default: not heated)	M13
CO₂ range¹⁾	0...2000 ppm	HV1
	0...5000 ppm	HV2
	0...1 % (10000 ppm)	HV3
	0...3 % (30000 ppm)	HV5
	0...5 % (50000 ppm)	HV6

1) The CO₂ range of the EE872S must be the same as of the original EE872 probe.

9 Technical Data

Measurands

CO₂

Measurement principle	Dual wavelength non dispersive infrared (NDIR)
Measurement range	0...2000 ppm: $< \pm (50 \text{ ppm} + 2 \% \text{ mv})$ <i>mv = CO₂ measured value</i>
Accuracy at 25 °C (77 °F) and 1013 mbar (14,69 psi)	0...5000 ppm: $< \pm (50 \text{ ppm} + 3 \% \text{ mv})$ 0...10000 ppm: $< \pm (100 \text{ ppm} + 5 \% \text{ mv})$
	0...3 %: $< \pm (1.5 \% \text{ from full scale} + 2 \% \text{ mv})$
	0...5 %: $< \pm (1.5 \% \text{ from full scale} + 2 \% \text{ mv})$
Response time $t_{63}^{1)}$	90 s
T dependence, typ. (-20...45 °C) (-4...113 °F)	$\pm (1 + \text{mv} [\text{ppm}] / 1000) \text{ ppm}/^{\circ}\text{C}$, for CO ₂ <10000 ppm $-0.3 \% \text{ mv} / ^{\circ}\text{C}$, for CO ₂ > 10000 ppm
Residual pressure dependence ²⁾ (-20...45 °C) (-4...113 °F)	0.014 % mv / mbar (ref. to 1013 mbar)
Measurement interval	15 s (user adjustable from 15 s to 1 h)
Long term stability, typ. at 0 ppm CO ₂	20 ppm / year

Relative humidity

Working range	0...100 % RH, with enabled heating 0...95 % RH (non-condensing), with disabled heating
Accuracy ³⁾ at 25 °C (77 °F)	$\pm 3 \% \text{ RH}$ (20...80% RH) $\pm 5 \% \text{ RH}$ (0...95% RH)

Pressure

Working range	700...1100 mbar (10.15...15.95 psi)
Accuracy at 25 °C (77 °F), typ.	$\pm 2 \text{ mbar}$
Temperature dependence	$\pm 0.016 \text{ mbar/K}$, 0...60 °C (0...140 °F)

Temperature

Working range	-40...60 °C (-40...140 °F)
Accuracy ³⁾ at 5...60 °C (41...140 °F), typ.	$\pm 0.5 \text{ }^{\circ}\text{C}$ ($\pm 0.9 \text{ }^{\circ}\text{F}$)

Outputs

Analogue (CO₂ only)	0 - 5 V / 0 - 10 V -1 < I _L < 1 mA 0 - 20 mA / 4 - 20 mA (3-wire) Load resistance ≤ 500 Ohm
Digital interface (CO₂, RH, T, p, Td)	RS485 (EE872 = 1/10 Unit Load)
Protocol	Modbus RTU
Default settings ⁴⁾	Parity even, 1 stop bit, Modbus address 237
Protocol	BACnet MS/TP
Default settings ⁵⁾	BACnet address 6

General

Power supply class III 	15 - 35 V DC ⁶⁾ for current output 12 - 30 V DC for voltage output and RS485 interface
Average current consumption at 24 V DC and 15 s measurement interval	37 mA for 20 mA output current 17 mA for voltage output and RS485 interface
Peak current, max.	200 mA
Enclosure material	Plastic (PET), UL94HB approved or Stainless steel 1.4404
Filter cap material	PTFE, UL94V-0 approved
Protection rating	IP65
Electrical connection	M12x1, stainless steel 1.4404
Electromagnetic compatibility	EN 61326-1 EN 61326-2-3 Industrial Environment FCC Part15 Class A ICES-003 Class A
Storage conditions	-40...60 °C (-40...140 °F) 700...1100 mbar (10.15...15.95 psi) 0...95 % RH non-condensing

1) With data averaging algorithm for smooth output signal. Faster response time available upon request.

2) Pressure dependence of a device without pressure compensation: 0.14 % mv/mbar.

3) At 24 V DC supply, air flow min. 0.3 m/s, probe horizontal or with sensing head downwards, excl. hysteresis.

4) More details about communication setting and the Modbus map: See User Manual and Modbus Application Note at www.epluse.com/ee872.

5) The EE872 PICS (Product Implementation Conformance Statement) is available on the website at www.epluse.com/ee872.

6) USA & Canada class 2 supply required, max. supply voltage 30 V DC





HEADQUARTERS

E+E Elektronik Ges.m.b.H.

Langwiesen 7
4209 Engerwitzdorf
Austria
Tel.: +43 7235 605-0
E-mail: info@epluse.com
Web: www.epluse.com

SUBSIDIARIES

E+E Elektronik China

18F, Kaidi Financial Building,
No.1088 XiangYin Road
200433 Shanghai
Tel.: +86 21 6117 6129
E-mail: info@epluse.cn

E+E Elektronik France

47 Avenue de l'Europe
92310 Sèvres
Tel.: +33 4 74 72 35 82
E-mail: info@epluse.fr

E+E Elektronik Germany

Schöne Aussicht 8 C
61348 Bad Homburg
Tel.: +49 6172 13881-0
E-mail: info@epluse.de

E+E Elektronik Italy

Via Alghero 17/19
20128 Milano (MI)
Tel.: +39 02 2707 86 36
E-mail: info@epluse.it

E+E Elektronik Korea

Suite 2001, Heungdeok IT
Valley Towerdong, 13,
Heungdeok 1-ro, Giheung-gu
16954 Yongin-si, Gyeonggi-do
Tel.: +82 31 732 6050
E-mail: info@epluse.co.kr

E+E Elektronik USA

333 East State Parkway
Schaumburg, IL 60173
Tel.: +1 847 490 0520
E-mail: office@epluse.com

YOUR PARTNER IN SENSOR TECHNOLOGY



ELEKTRONIK®
Ges.m.b.H.